

TransCon-e Electric Model HTSBEL



Rugged... Durable... Harlan



The Harlan Model HTSBEL Lithium-ion powered baggage/cargo tractor was developed to meet the demands of the growing market for Lithium powered electric vehicles. With many of these units in service since 2014 Harlan has the experience needed for this new technology.

This popular electric package in the familiar baggage/cargo tractor frame aircraft is crafted to meet the challenging demands of ramp life. Some options include complete cab assembly, heat/defrost, mirrors, beacons, variety of hitches and suspension style seats.

Standard Features

High Efficiency AC Motor allows for longer duty cycles between charges

AC Pump Motor

Keyless or Keyed master Switch

Two LED Headlights and turn signals

Combination LED Tail/Stop Light & Back-up

Light Safety kill switch on driver's seat

Electric Actuated Park Brake

LCD Dash Display

Fwd & Rvs Inching

Standard Driver and Passenger seat

Retractable Seatbelts

Rear Mount E-Hitch



Specifications

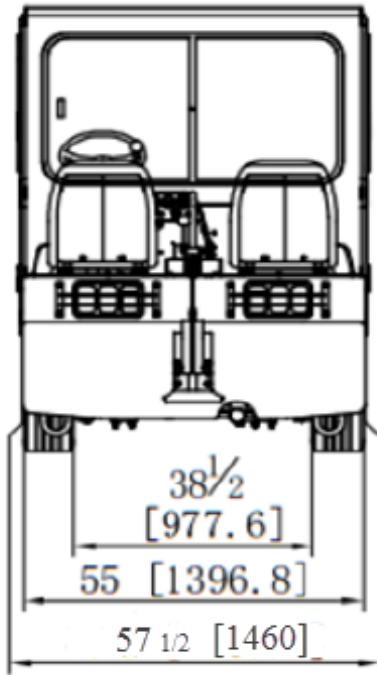

Length
105.75" (2687mm)
w/ rear hitch: 113" (2891 mm)

Width
57.5" (1460 mm)

Height
56.5" (1435 mm)
w/ Cab 81.5" (2070 mm)

Wheel Base
60 3/8" (1534 mm)

Ground Clearance
7.75" (196.8mm)

Integrated Drive Axle
Fully integrated with AC
Induction Motor

Steer Axle
Heavy-Duty Dual Shaft with
two tapered roller bearings

Towing Coupler
E-Hitch with 1" pin (other hitch
options available)

Tires
Front: 165/R13
Back: LT225/75R16

Controller
Curtis Programmable

Energy Source
80V Lithium-ion

Charging Options
-On Board Charger
-EV Interface (used w/on board)
-Fast Charge connection set-up

Steering System
Hydrostatic

Service Brakes

Primary: 4-Wheel Hydraulic

Secondary: Traction motor
braking with regen

Suspension
Front: Leaf spring

Rear: Coil spring w/ Shocks

Park Brake

Electrically actuated

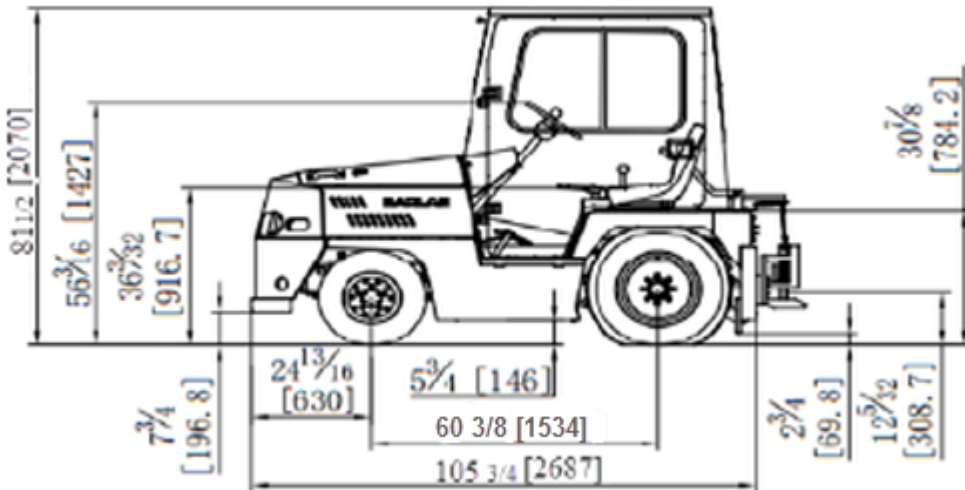

DRAW BAR PULL

HTSBEL40	HTSBEL50	HTSBEL60
4,000 lbs. (17.8N)	5,000 lbs. (22.2kN)	6,000 lbs. (26.7kN)

